

### DN 100–400 Standardausführung

- Betätigung mittels elektrischem Drehantrieb 3×400 V Drehstrom, 50 Hz, steigende Spindel
- Werkstoffe gemäss Datenblatt 2.0.13
- Korrosionsschutz gemäss Datenblatt 2.0.12
- Flanschbohrung: PN 25 EN 1092 / ISO 7005 (DIN 2501)
- Baulänge: EN 558 / ISO 5752 Series 16 (DIN 3202 K3)
- Nenndruck PN: 25 bar
- Dichtheitsprüfung gemäss EN 12266 Leckrate A

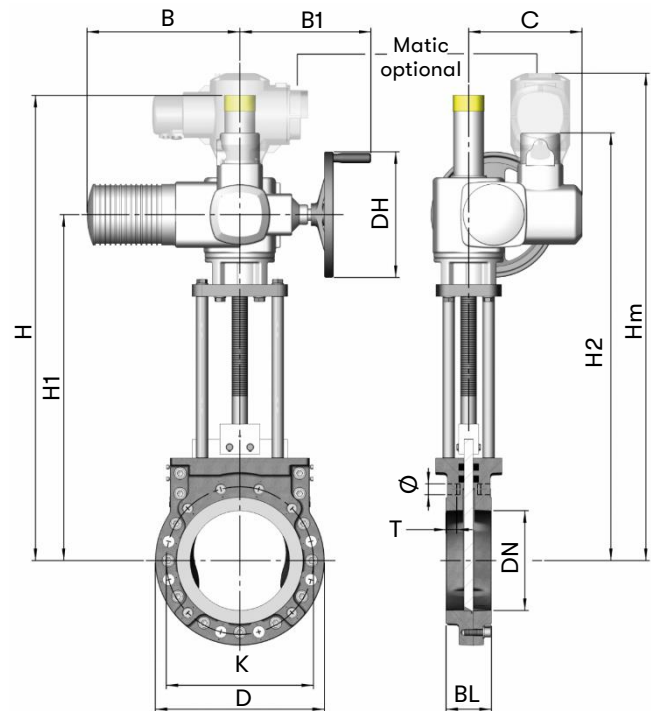

DN	D	K	BL	Ø	T	Schrauben	Gewinde	Durchgehend	Antrieb*							Gewicht		
									Typ SA	H	H1	H2	Hm	DH	B		B1	C
100	235	190	64	M20	15	8 Stck	4 Stck	4 Stck	7.6 <sup>1</sup>	585	498	708	838	200	265	249	238	45 kg
									10.2 <sup>1</sup>	595	500	710	840	200	283	254	248	50 kg
125	270	220	70	M24	17	8 Stck	4 Stck	4 Stck	7.6	647	560	770	900	200	265	249	238	53 kg
									10.2	657	562	772	902	200	283	254	248	58 kg
150	300	250	76	M24	17	8 Stck	4 Stck	4 Stck	10.2	775	583	793	928	200	282	254	247	68 kg
									14.2 <sup>1</sup>	821	683	839	1038	315	384	336	222	100 kg
200	360	310	89	M24	21	12 Stck	6 Stck	6 Stck	10.2	929	737	947	1082	200	282	254	247	98 kg
									14.2	975	787	993	1142	315	384	336	285	125 kg
250	425	370	114	M27	27	12 Stck	6 Stck	6 Stck	14.2	1055	867	1073	1222	315	384	336	285	165 kg
									14.6	1055	867	1073	1222	400	384	338	285	178 kg
300	485	430	114	M27	27	16 Stck	6 Stck	10 Stck	14.2	1275	967	1193	1342	315	384	336	285	205 kg
									16.2	1226	1002	1232	1422	500	510	363	330	250 kg
350	555	490	127	M30	31	16 Stck	6 Stck	10 Stck	14.2	1358	1050	1276	1425	315	384	336	285	260 kg
									14.6	1358	1050	1276	1425	400	384	338	285	268 kg
400	620	550	140	M33	35	16 Stck	6 Stck	10 Stck	16.2	1409	1085	1315	1505	500	510	363	330	305 kg
									14.2	1581	1173	1399	1548	315	384	336	285	340 kg
									14.6	1581	1173	1399	1548	400	384	338	285	342 kg
									16.2	1532	1208	1438	1628	500	510	363	330	380 kg

\* Antriebszuordnung je nach Einsatzbedingung

<sup>1</sup> 45° versetzt