

DN 100–400 Standardausführung

- Betätigung mittels doppel wirkenden ölhydraulischem Zylinder
- Steuerdruck 120 bar
- Werkstoffe gemäss Datenblatt 2.0.13
- Korrosionsschutz gemäss Datenblatt 2.0.12
- Flanschbohrung: PN 25 EN 1092 / ISO 7005 (DIN 2501)
- Baulänge: EN 558 / ISO 5752 Series 16 (DIN 3202 K3)
- Nenndruck PN: 25 bar
- Dichtheitsprüfung gemäss EN 12266 Leckrate A

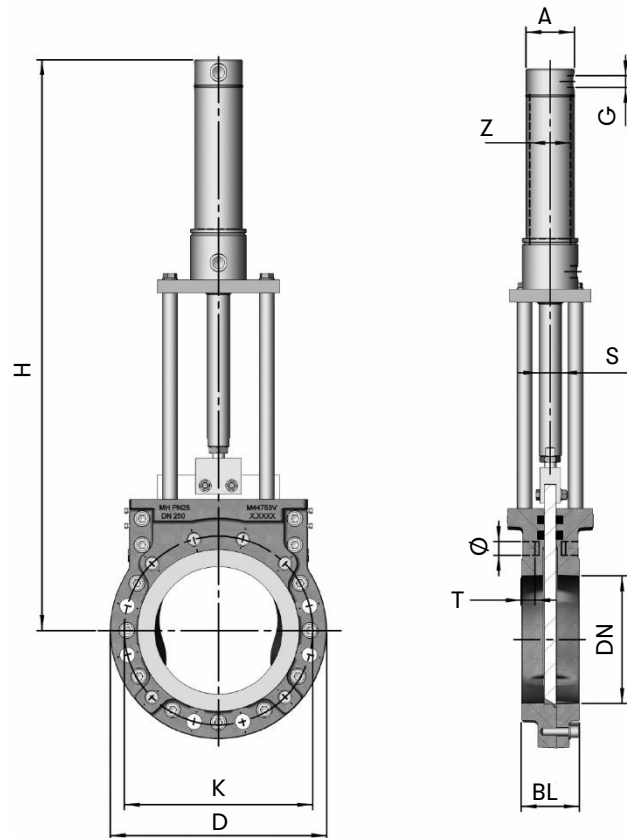

DN	D	K	BL	Ø	T	Schrauben	Gewinde	Durchgehend	Antrieb*				Gewicht	
									Z	S	H	A		
100	235	190	64	M20	15	8 Stck	4 Stck	4 Stck	40	22	581	50	G 3/8"	30 kg
									50	28	603	60	G 3/8"	32 kg
									63	36	640	75	G 1/2"	35 kg
125	270	220	70	M24	17	8 Stck	4 Stck	4 Stck	40	22	668	50	G 3/8"	39 kg
									50	28	690	60	G 3/8"	40 kg
									63	36	707	75	G 1/2"	42 kg
150	300	250	76	M24	17	8 Stck	4 Stck	4 Stck	50	28	736	60	G 3/8"	46 kg
									63	36	753	75	G 1/2"	49 kg
									80	45	840	95	G 3/4"	59 kg
200	360	310	89	M24	21	12 Stck	6 Stck	6 Stck	50	28	935	60	G 3/8"	72 kg
									63	36	952	75	G 1/2"	75 kg
									80	45	989	95	G 3/4"	86 kg
250	425	370	114	M27	27	12 Stck	6 Stck	6 Stck	63	36	1082	75	G 1/2"	110 kg
									80	45	1119	95	G 3/4"	121 kg
									100	56	1127	115	G 3/4"	135 kg
300	485	430	114	M27	27	16 Stck	6 Stck	10 Stck	63	36	1252	75	G 1/2"	149 kg
									80	45	1289	95	G 3/4"	161 kg
									100	56	1297	115	G 3/4"	175 kg
350	555	490	127	M30	31	16 Stck	6 Stck	10 Stck	80	45	1423	95	G 3/4"	231 kg
									100	56	1431	115	G 3/4"	225 kg
									125	70	1537	140	G 3/4"	231 kg

Masse in mm. Alle Angaben unverbindlich.
Änderungen vorbehalten.

DN	D	K	BL	Ø	T	Schrauben	Gewinde	Durchgehend	Antrieb*					Gewicht
									Z	S	H	A	G ISO 228	
400	620	550	140	M33	35	16 Stck	6 Stck	10 Stck	80	45	1596	95	G 3/4"	304 kg
									100	56	1604	115	G 3/4"	317 kg
									125	70	1637	140	G 3/4"	345 kg
									140	80	1667	170	G 1"	381 kg

* Antriebszuordnung je nach Einsatzbedingung